

The tap that does it all

100°C boiling, filtered chilled and sparkling water



Quooker®

The tap that does it all



Quooker's story started in 1970. Rotterdam-born Founder Henri Peteri was working at Unilever in the 1970s as part of the development team that invented instant soup. He believed that waiting for the kettle to boil meant that the soup was not truly instant. Born from his exasperation of waiting was the gem of an idea, instant boiling water, on tap. Peteri left Unilever and worked tirelessly in his basement to engineer a tap that could dispense instant, true 100 °C water. Yet it wasn't until the early 1990s that the first Quooker tap was ready to be commercially launched in the Netherlands.

Now, Quooker produces over 200,000 Quookers a year, there are over 1 million in use throughout Europe and the UK.

The Peteri brothers always aimed to produce the most sustainable, energy-efficient and high-quality product. Now they head an internationally successful company. But, continuing in the spirit of their late father, they are still innovating.

Quooker®



Fusion Square black

Using a Quooker

Make coffee

Instant soup

Boil potatoes

Cook noodles and rice

Clean greasy pans

Clean chopping boards

Poach fish

Boil eggs

Pre-heat plates

Poach vegetables

Prepare baby bottle

Make tea

Sterilise dummies

Prepare sauce

Clean mixer

Skin tomatoes

Make broth or soup

Remove candle wax

Clean filter

Rinse plates

Filtered water

Make cocktails

Enjoy sodawater

The advantages of a Quooker



Safe

With a Quooker it's impossible to turn the boiling on accidentally. It requires a double-push and turn on an inconspicuous ring mechanism, which is completely separate from the regular cold and hot. The water is injected with air, and so is a fine spray which ensures the avoidance of accidental scalds or burns. Quookers have a double insulated spout, and so are cool to the touch, unlike kettles. Last but not least, you cannot accidentally knock, tip or 'spill' a Quooker as one can with a kettle or pan of boiling water.

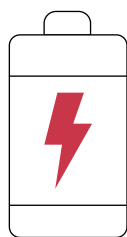

Energy efficient

Anyone who needs boiling water several times a day will not use more energy with a Quooker than with a kettle. With a Quooker COMBI tank (which provides both boiling and hot water all from a cold feed), you can even save energy. This is the first 'boiler' in the world with high-vacuum insulation, using 50 percent less energy than a household boiler. As the most energy-efficient hot water supply for the kitchen, the Quooker COMBI has an energy rating of A. Make your purchase even more sustainable by adding a Quooker CUBE that makes plastic water bottles redundant.

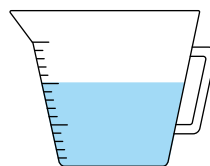

Water efficient

We all know it's important to be economical with water and yet, so many households unnecessarily waste it both in small amounts – for example if you boil twice as much water as you need – but also in larger amounts, when you let the tap run for a while until the water heats up. A Quooker helps you prevent wastage like this. With a Quooker CUBE, which also dispenses cool sparkling and filtered water, you also save on plastic water bottles!

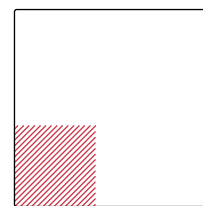

Space saving

Do you have a small kitchen? A Quooker saves precious space on your worktop. The space occupied by a kettle can be freed up to slice, knead and chop. And because the tank is so compact, there's still usable space under your worktop or in your kitchen cupboard.



Versatile

A Quooker is a kitchen appliance that can be used for a multitude of tasks. Whether it is tea or coffee, blanching vegetables or sterilising baby bottles or even cleaning dirty pans, the Quooker can do it all! With the Quooker Flex, which is equipped with an extendable hose, rinsing your sink or cleaning that chopping board just became even easier. The Quooker is also a great choice if you're looking to maximise work-top space and be rid of unsightly wires!

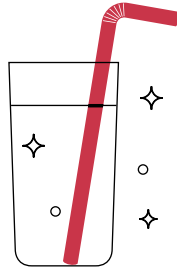

Tasty

How does it taste? Well.. An active carbon filter in the tank purifies every delivery of boiling water. Furthermore, because the tank keeps it under pressure, at a temperature of 110 °C it remains constantly fresh. This technology keeps the water hot without needing to use much energy, which translates to very minimal running costs. The Quooker CUBE is fitted with a Hollow Fibre filter and an Active Carbon filter that removes any bacteria from the water, giving you instantly chilled, fresh water every time.

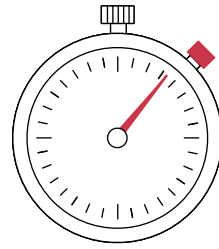

Time saving

The average person spends four months of their life waiting for a kettle to boil – but with Quooker, you'll never have to wait for your kettle to boil again! Once installed, the Quooker will undoubtedly become your most used appliance in the kitchen. As the boiling tank is constantly replenishing, you'll always have instant, fresh boiling water on tap. With our CUBE accessory, you will also have filtered chilled and sparkling water at your fingertips, meaning less supermarket trips for bottled water!

Choose your tap



Flex stainless steel

Front



Height: 255 mm
Reach: 292 mm
Tap hole: Ø 35 mm
Rotation: 270 °



stainless steel



black

Flex



Height: 412 mm
Reach: 220 mm
Tap hole: Ø 35 mm
Rotation: 270 °



polished chrome



stainless steel



black

Fusion Square



Height: 291mm
Reach: 220mm
Tap hole: Ø 35 mm
Rotation: 360 °



polished chrome



stainless steel



black



patinated brass



gold

Fusion Round



Height: 366 mm
Reach: 220 mm
Tap hole: Ø 35 mm
Rotation: 360 °



polished chrome



stainless steel



black



patinated brass



gold

Classic Fusion Square



Height: 291 mm
Reach: 220 mm
Tap hole: Ø 35 mm
Rotation: 360°



polished
chrome



stainless
steel



patinated
brass

Classic Fusion Round



Height: 366 mm
Reach: 220 mm
Tap hole: Ø 35 mm
Rotation: 360°



polished
chrome



stainless
steel



nickel



patinated
brass

Classic Nordic Square single tap



Maximum-height: 350 mm
Minimum-height: 115 mm
Reach: 160 mm
Tap hole: Ø 32 mm



polished
chrome



stainless
steel

Classic Nordic Round single tap



Maximum-height: 405 mm
Minimum-height: 170 mm
Reach: 160 mm
Tap hole: Ø 32 mm
Rotation: 360°



polished
chrome



stainless
steel



nickel

Nordic Square Twintaps

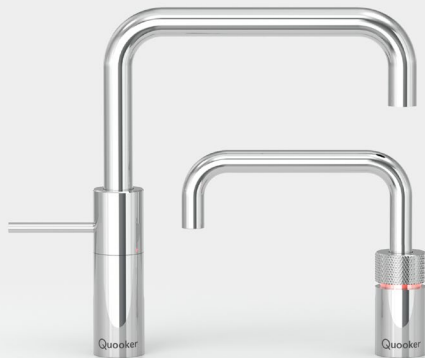

Height: 270 mm
Reach: 220 mm
Tap hole: Ø 35 mm
Rotation: 360°

Maximum-height: 350 mm
Minimum-height: 115 mm
Reach: 160 mm
Tap hole: Ø 32 mm
Rotation: 360°



polished
chrome



stainless
steel

Nordic Round Twintaps



Height: 345 mm
Reach: 220 mm
Tap hole: Ø 35 mm
Rotation: 360°

Maximum-height: 405 mm
Minimum-height: 170 mm
Reach: 160 mm
Tap hole: Ø 32 mm
Rotation: 360°

Nordic Square single tap



Maximum-height: 350 mm
Minimum-height: 115 mm
Reach: 160 mm
Tap hole: Ø 32 mm
Rotation: 360°



polished
chrome



stainless
steel

Nordic Round single tap



Maximum-height: 405 mm
Minimum-height: 170 mm
Reach: 160 mm
Tap hole: Ø 32 mm
Rotation: 360°



Nordic soap dispenser gold and Fusion Square gold



Nordic soap dispenser gold and Fusion Round gold

The tanks

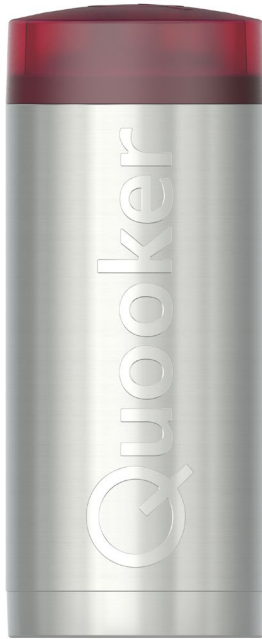
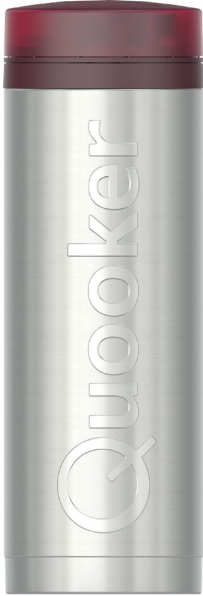

PRO3

Provides three litres of instant boiling water.

Diameter	153 mm
Height	467 mm
Heating-up time	10 minutes*
Power	1600W
Standby power consumption	10W
Volume 100°C	3 litres
Energy label	none**
Mounting bracket available	yes

PRO7

Provides seven litres of instant boiling water.

Diameter	199 mm
Height	468 mm
Heating-up time	20 minutes*
Standby power consumption	10W
Volume 100°C	7 litres
Energy label	none**
Mounting bracket available	yes

COMBI

Provides seven litres of instant boiling water or 27 litres of hot water (40°C) all from a cold feed.

No more waiting for hot water with the Quooker COMBI or dealing with low hot water pressure. Furthermore, it is the first 'boiler' with high-vacuum insulation. This makes it the most energy-efficient hot and boiling water provision for the kitchen.

Diameter	200 mm
Height	472 mm
Heating-up time	20 minutes*
Standby power consumption	10W
Volume 100°C	7 litres
Volume 60°C	15 litres
Volume 40°C	27 litres
Energy label	A
Mounting bracket available	yes

* These values are averages. ** PRO3 and PRO7 tanks only produce boiling water. The EU has no energy label guideline for boiling water tanks. However, these tanks are equally economical.

Choose your tank

Which tank will best suit your kitchen?

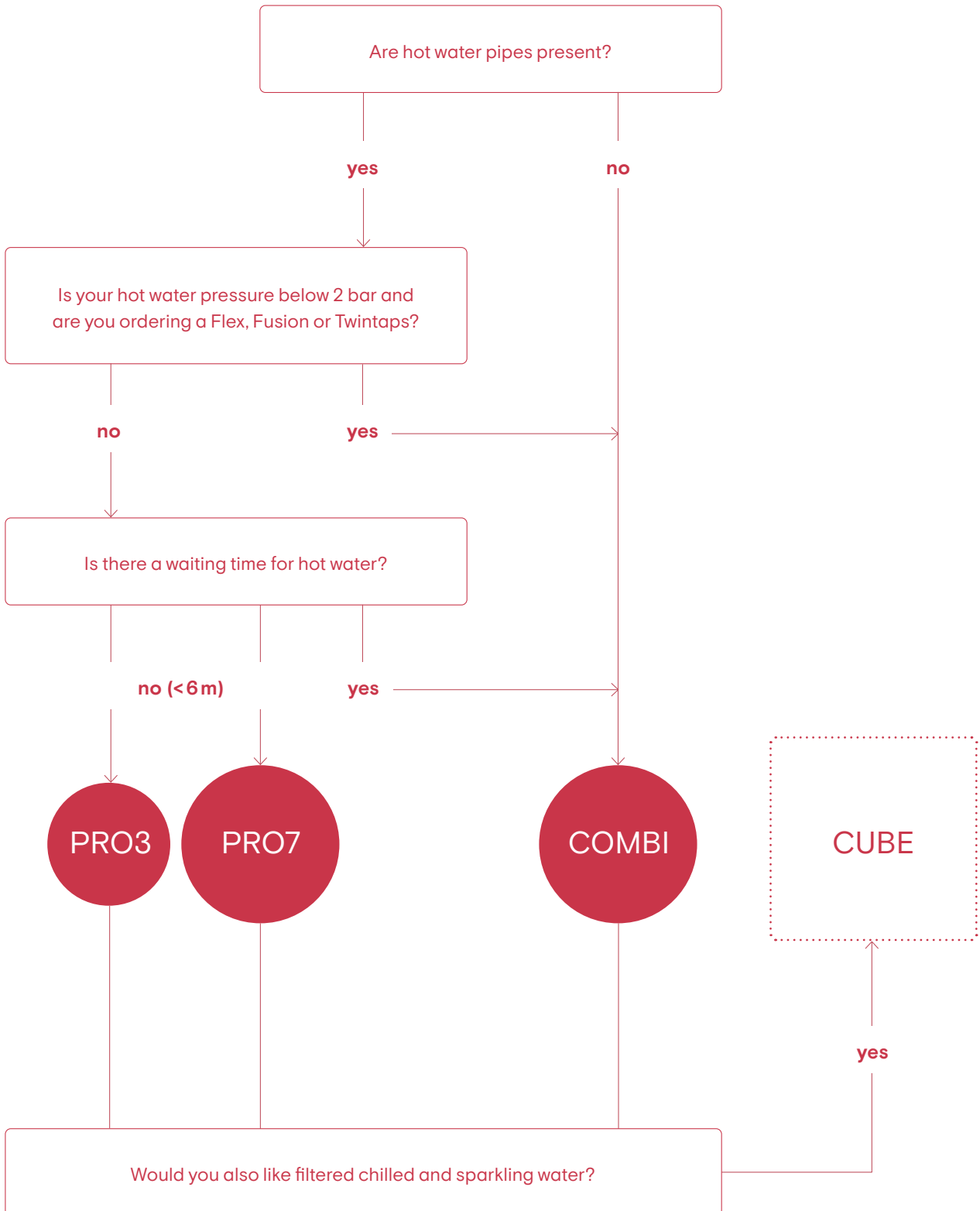



Quooker

Flex stainless steel

Quooker CUBE



With the CUBE, your Quooker will dispense filtered chilled and sparkling water in addition to 100 °C boiling, hot and cold water. The CUBE contributes to sustainable living by eliminating the need to purchase single-use plastic bottles and helps to lower your carbon footprint by reducing supermarket visits. Not to mention, there will be no more carrying heavy bottles! With the CUBE you can make the most delicious lemonades and cocktails in no time, or just enjoy a glass of crisp, cold water.

The CUBE has a CO₂ cylinder attachment from which you can draw up to 60 litres of cold sparkling water. It will be placed at the bottom of your kitchen cupboard next to the existing boiling water tank. If you're short of plug sockets, we offer a Quooker Powerswitch. In addition to being handy, it also

prevents the circuit from overloading by switching the Quooker tank to standby mode if too much power is drawn from another appliance. The filtered chilled and sparkling water will still operate as normal.

Measurements

Height: 500 mm

Width: 153 mm*

Depth: 270 mm*

Chilling time: 30 min

Standby consumption: 5 W

* When the CO₂-cylinder is connected, 70 mm extra space is required at the front or side of the CUBE.

Measurements

Height: 230 mm

Diameter: 100 mm



Nordic Square Twintaps stainless steel

Accessories

Soap dispenser

This soap dispenser makes a great combination with a Quooker tap. It can be operated with one hand and is easy to fill from the top. This is the first soap dispenser that uses a patented ball bearing system and solid metal internals.



Cold Water Filter

The Cold Water Filter has been designed to allow you to quickly switch from tap water to cold filtered water. The Quooker tap supplies cold filtered water via a single push and turn which will light the tap ring blue. The water passes through an activated-carbon filter which ensures the water tastes and smells better. The filter is easy to replace and must be changed every 12 months. A Cold Water Filter is not necessary when you have purchased a CUBE.



Scale Control R

The Scale Control R has been developed to lengthen the lifespan of your Quooker, and reduces the hardness of the water to prevent limescale build-up in the tank. It is the most reliable descaling solution for the Quooker and improves the taste of the Quooker water.

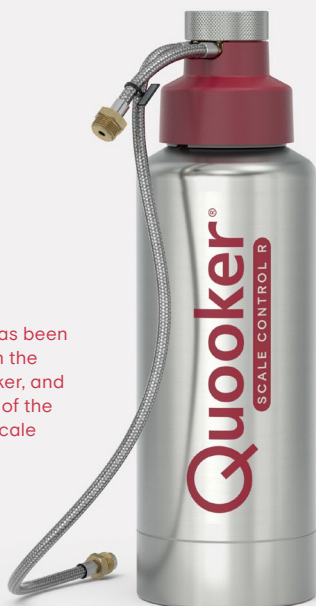

Powerswitch

The Powerswitch for Quooker and CUBE is a three-way adaptor that will allow you to connect the Quooker tank, the Quooker CUBE and another appliance, for example a dishwasher, to the same socket. It prevents the circuit from overloading as it will detect when the third-party appliance is in use and will switch the Quooker tank to standby mode if too much power is drawn by the other appliance. The chilled filtered and sparkling water will operate as normal.





Classic Fusion Round patinated brass

A world class service and business philosophy



With over 40 years' experience and over 1 million installations, Quooker is the trusted name in the provision of 100 °C boiling, hot, cold, chilled and sparkling water. The business' DNA is all about providing an unparalleled world class service adopting a unique approach with a true desire to be the best in class at everything and anything we do.

A Quooker is easy to maintain which increases its longevity. Our taps typically last between fifteen and twenty years and all of our systems are maintained by a dedicated team guaranteeing a prompt and reliable service.

Sustainability is also at the centre of our DNA with people and protection of the planet at the forefront of our minds. Our factory is covered with 900 solar panels which supplies all of our energy needs! We recycle old products and manage our waste flows in a sustainable way.



Virtual appointment

With our virtual appointment service we will be able to guide you through our full collection, ensuring we find the system which best suits you!



Augmented reality

Quooker augmented reality allows you to virtually place the tap of your choice in your own kitchen in a fun and easy way. This way you can instantly visualise how any Quooker tap will look and fit your kitchen.



